



PMC Controller Electrical Manual

Table of Contents

Electrical Installation.....	3
Overview.....	3
IO Overview.....	3
Inputs.....	3
Encoders (A / A B / B Z / Z).....	3
Analogue Input (ADC0-3).....	4
Digital Inputs (Inp0-15).....	4
Optional Inputs (IP16-19).....	6
Outputs.....	6
Motor Control DAC Outputs (MC0-3).....	6
TTL Outputs (TTL0-7).....	6
Driver Outputs (DRV8-19).....	7
Servo Amplifier ENABLE (ENE, ENC).....	8
Serial.....	8
Wiring.....	9
Motors.....	10
Connectors.....	10
Grounding the Power Supply.....	10
DAC Wiring.....	10
Input Cable Wiring.....	11
Wiring to Drivers.....	11
Analogue Input Wiring.....	11
General.....	11
Keypad.....	11
Keypad LED's.....	12
Overlay.....	12
Power Supply.....	12
Pinout Connections.....	13

Electrical Installation

Overview

The PMC series of controllers has a variety of IO to suit many different machines. Once the hardware is wired the software needs to be setup to work correctly with the IO's that have been chosen.

This manual will cover the wiring aspect of the controller, please refer to the appropriate software manual for system setup.

IO Overview

37 way D Type:

- 12x +24V Outputs (DRV8-19)
- 16x Opto Isolated Inputs (INP0-15)
- 4 Multifunction Inputs (INP16-19)
- 24V DC PSU Connections

44 way D Type:

- 4x Analogue Inputs (ADC0-3)
- 4x Encoder Ports (A, /A, B, /B, Z, /Z)
- 8x TTL Level Outputs (TTL0-7)
- 4x +/-10V Motor Control DAC Outputs (MC0-3)
- +5V DC Output (+5VE)
- Analogue Grounds (AGND)
- Drive Enable Connections (ENA C & E)

9 Way D Type:

- 1x RS232
- 1x RS485
- 1x CAN

Inputs

The controller has a number of inputs types as listed below:

Encoders (A /A B /B Z /Z)

The encoder inputs are in addition to the digital inputs and are located on the 44 way D type connector. There are various types of encoder available, most of which can be used with the PMC's input configuration, some of which are Line Driver and NPN open collector.

Theoretically, the maximum input frequency is 1 MHz, but in reality most encoders produce an output of less than 100 kHz. Typically this would result in the use of a 1000 PPR encoder however to calculate accuracy the number of pulses needs to be

divided by the distance moved in one rotation. If working to a very fine accuracy a 2500ppr encoder could be used. In some exceptional cases an encoder may run at around 300 kHz. A five volt, 500 mA supply is provided by the controller for the encoders.

The encoders should use continuous screened cable, the screen of which, should be terminated at the controller end only. This will avoid ground loops and other interference problems. Note that the encoder signal required are A, B, /A and /B.

WARNING! ENCODER CABLES SHOULD BE ROUTED AWAY FROM ELECTRICALLY NOISY CABLES SUCH AS MOTOR SUPPLIES etc.

Analogue Input (ADC0-3)

4 Analogue inputs are provided located on the 44 way D type connector. The input voltage range is +/- 2 volts and the amplifier is of a high impedance type, the frequency response is greater than 100Khz. The ADC is a 12 bit signed type and is polled more than 1000 times per second.

The input voltage range of the amplifier can be altered by fitting a resistor in series with the input however please contact TRM for further information. If the voltage range is required to operate at voltages less than 2000 mV the amplifier may be altered as a factory option or alternatively the use of an external voltage amplifier is suggested.

The actual voltage range of the ADC is +/- 2047 mV. Zero volts input results in a zero count (the ADC is not auto zeroed and therefore there may be small errors around zero. A voltage of 2000 mV will produce a count of 2000 the resolution is therefore 1 mV.

Digital Inputs (Inp0-15)

The controller has 16 opto isolated and over-voltage protected inputs located on the 37 way D type connector. Isolation from the outside world is important for noise immunity and also helps to filter out unwanted noise spikes that could toggle the input. The digital inputs have a frequency range exceeding 10 kHz, although in most control loops sampling these at greater than 1 kHz would require too much of the systems resources and would be unnecessary.

Note: If the TRM interface card is used then Input 4 is used and should not have any other sensors connected to it.

It is possible to set the inputs to be active high or active low via MAP as the figure below shows:

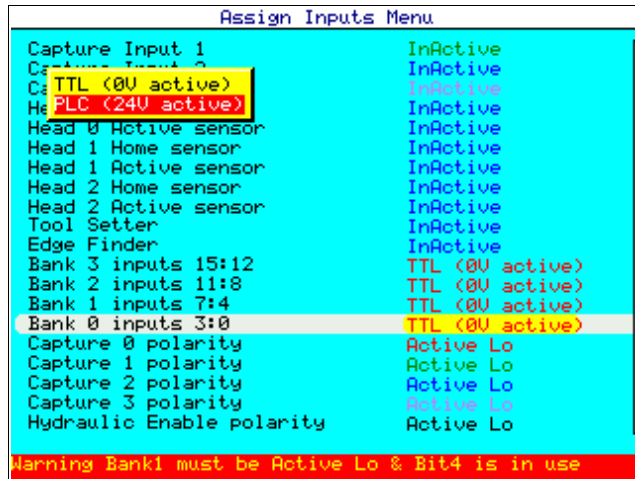

When an Input is selected active high it means the controller will read a '1' when active, in this case when the input reads any voltage between 5 to 48 Vdc . The configuration is as follows:

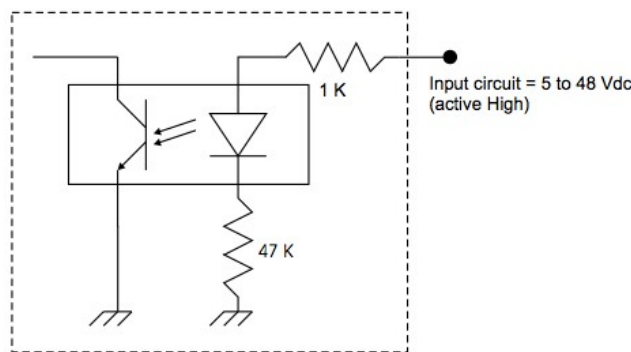

When a input is selected active low it means the controller will read a '1' when active, in this case when the input reads 0V. The configuration is as follows:

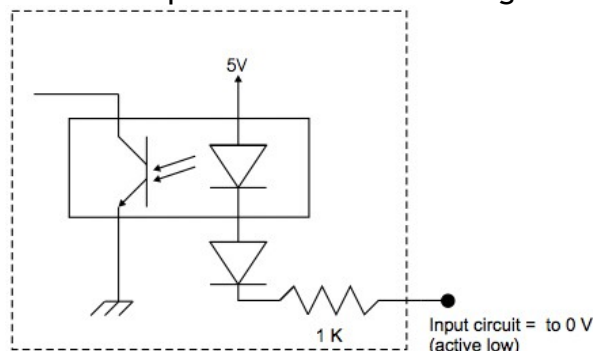

WARNING! DO NOT CONNECT THE INPUTS TO A NEGATIVE OR AC. SUPPLY, SINCE THIS MAY CAUSE DAMAGE DUE TO EXCESSIVE CURRENT FLOW.

Optional Inputs (IP16-19)

There are 4 inputs that are attached to the last 4 power driver pins DRV16-19. These inputs can be used to monitor the state of the output pin or as extra inputs however if they are used as dedicated inputs they cannot be used as outputs.

Outputs

The TRM controllers have a range of outputs to suit a variety of situations. This allows for devices to be driven directly or for signals to be sent to other modules.

Motor Control DAC Outputs (MC0-3)

4 output channels are provided at +/- 10 volts and located on the 44 way D type connector. With a maximum output impedance of 2200 ohms (with respect to the 0 volt rail) and is provided for motor control. Great care must be taken not to short the output to the 0v rail, or to subject it to an inrush of current etc. The DAC output stage incorporates a transient suppression device to protect the output in the event of a voltage discharge.

The DAC may be updated at intervals as low as 244 microseconds and has a resolution of 16 bits. This can be used as 11 bits in each direction. i.e. 32768 representing +10 volts, -32767 representing -10 volts and 0 representing 0 volts. This gives a system resolution of 305 micro-volts per digital increment, which produces extremely fine control.

TTL Outputs (TTL0-7)

The TRM controllers have 8 TTL outputs and also high power open drain Mosfet outputs. The TTL outputs are located on the 44 way D type connector configuration is shown below:

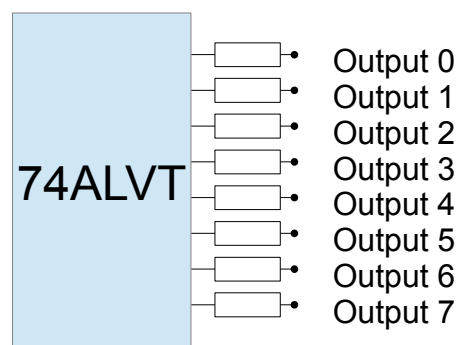

The output of the IC is connected via 33R resistors to limit noise and damage to the circuit. PMC outputs +/- 35mA @ 5V. This means that basic signals can be sent and LED's activated. If more voltage or current is required to say drive a relay then drivers 8+ can be used; see following section.

Note: If the Rev 1.0 TRM interface card is used Output 7 and 4 are used as a signal to the controller. Nothing further should be connected to these outputs.

Driver Outputs (DRV8-19)

The driver outputs are active high and can be operated at any voltage from 12V to 36V at 1 amp via a connection to the VDDIO pins. These are located on the 37 way D type connector. Any number of drivers can be on at the same time providing a total of 6 amps is not exceeded, or heating of the connector pins may occur. Each driver has a freewheel diode and a capacitor to avoid damage to the drivers and to also suppress EMC emission. See figure below for a typical connection.

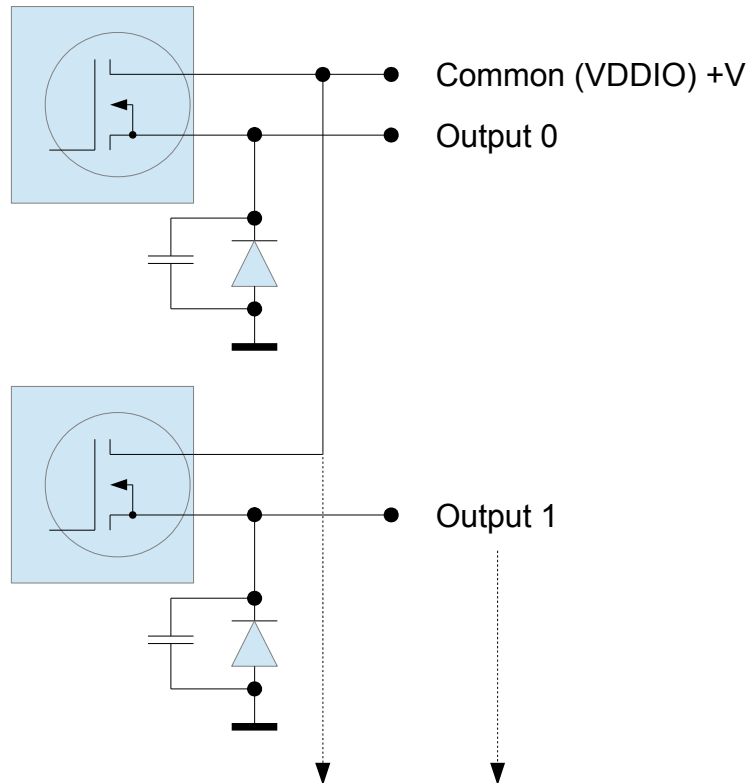

Should the drivers become accidentally reversed i.e. a negative voltage is applied to the drain with respect to the 0 volt rail, the diode will automatically conduct, clamping the maximum voltage to 0.7 of a volt with respect to ground, this prevents damage to the driver.

As an example, assume that we wish to switch a solenoid. A typical connection for such a device is to connect one side of the solenoid to the driver and the other side to GND. Once the driver is turned on the solenoid is activated. Turning the driver off removes the supply and the solenoid de-activates.

It is also advisable to suppress any transients at source and therefore connect a Freewheel diode directly across the coil of the solenoid to suppress back EMF at source.

Servo Amplifier ENABLE (ENE, ENC)

A single opto rated at 30V 10mA output is provided for enabling servo amplifiers. This is an uncommitted transistor output located on the 44 way D type connector with both pins being made available to allow high or low enable signals to be configured.

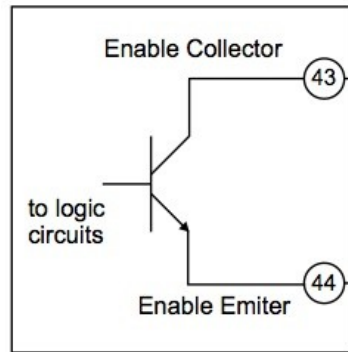

Please note that if there is a requirement to enable more than 2 drives in parallel the output will need to be buffered. This is due to the fact that most drives use an opto-isolated input that will need around 10mA to activate. TRM can supply a 4 output module to convert this if required which can be easily mounted on DIN rail.

Serial

The controller provides two external serial ports located on the 15 way High Density D type connector these are a full RS232 compliant serial interface with the following signals:-

- Rx - Receive
- Tx - Transmit
- RTS - Ready to send
- CTS - Clear to send

The second serial channel is dedicated to a four wire RS485 port. Both channels are controlled in the same manager software, accessed via the operating system. The baud rates can vary from 300 Hz to 230 kHz.

The RS232 port produces an output of plus and minus 10 volts in compliance with the RS232 directive.

The RS485 system consists of a UART and a duplex transceiver for RS-485 and RS-422 communication. The reduced slew-rate drivers minimise EMI and reduce reflections caused by improperly terminated cables, thus allowing error-free data transmission at data rates up to 213 KBPS.

Drivers are short-circuit current limited and are protected against excessive power dissipation by thermal shutdown circuitry that places the driver outputs into a high-

impedance state. The receiver input has a fail-safe feature that guarantees a logic-high output if the input is open circuit.

The transceiver features a quarter-unit-load receiver input impedance, allowing up to 128 transceivers on the bus, the transceiver is designed for half-duplex or full duplex applications.

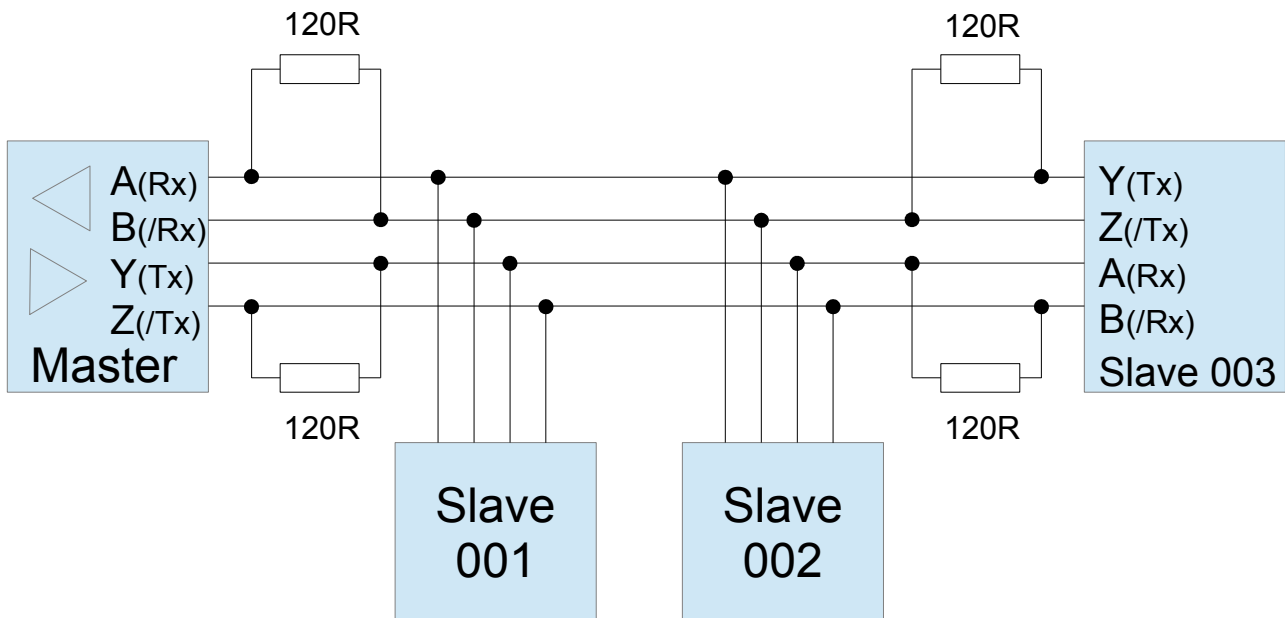

To minimise reflections, the line should be terminated at both ends in its characteristic impedance, and stub lengths off the main line should be kept as short as possible. The slew-rate-limited transceiver we use is more tolerant of imperfect termination. Nominal values for the termination resistors is 120 Ohms.

Wiring

This is a most important topic since bad wiring can cause major problems to any control system. In general it is wise to ensure that all inputs are run through screened cables, especially the encoder signals. It is also very important to wire the motor command signals from the controllers DAC'S using twisted pair screened cable with the screen terminated at the controller. Please remember that the encoder signals may have fast rise times and may produce substantial EMC.

Always ensure that the screened cables are properly grounded at one end only, it is preferable to ground the screen at the controller. It is recommended that the metal chassis of the cable 'D' connector be connected to the screen and therefore this grounds the screens to the controller case, which should be grounded.

Motor armature and other noisy cables should be routed in such a manner as to gain maximum distance between them and the signal cables to avoid crosstalk. If noise is induced into the command cable the system will become unstable and potentially crash.

Motors

The controller can control a range of different types of motor, for example:-

- DC Servo motors
- Inverters
- AC Servo motors
- Linear Motors

As the controller is only a low power unit it will be necessary to interface to the motors with a Drive of a suitable type and capacity for the application. The command signal to the drive should also be checked to ensure compatibility.

Most rotary motors can be controlled in either an open loop or closed loop process depending on the desired accuracy of the system. Linear motors and Fixed length(travel) axis would generally need an encoder feedback to ensure the controller knew where the axis was at any given time.

Connectors

The controller uses 'D' type connectors for all of its connections and it is recommended that good quality mating halves be used. It is worth remembering, the quality of your system depends largely on the integrity of the connectors. Always ensure that the connectors are gold plated and are of good quality.

Many people prefer to use solder bucket connectors since these are easily repaired. There are many manufacturers and specifications of D type connectors most of which are excellent products suitable for use with the Controller.

Where connectors with EMC filters built in are to be used it is important to remember that encoder signals are not to be filtered, as these contain high frequency pulses, which would be filtered out by the connectors resulting in errors in the motion control.

Grounding the Power Supply

It is very important to ensure that the power supply is connected to the ground rail at only one place only. As the controller is the analogue signal source as far as the very sensitive DAC signals are concerned. All signal grounds and screens are then connected to that one point. Note that if the power supply is grounded in multiple points it is possible that voltages that exist as a result of resistance in the cables may cause ground loops in the signal cables this may cause loss of stability in the motion control system.

DAC Wiring

The motor command signals must be returned to the controller ground. Each

amplifier must be wired with a unique ground and motor command signal preferably in screened twisted pair.

Within the 44 way 'D' connector of the controller is adequate provision to connect the grounds. Do not connect the screen at both ends but at the controller end only. Always ensure that there is no possibility of ground loops within the earth's or screens on any important signals such as the motor command.

Should ground currents become a problem in the system, motor stability may be impossible since it is not unknown for 20 - 30 mV of ripple to occur on badly grounded systems.

Input Cable Wiring

Treat all inputs as needing screened cables. Although the controller has opto-isolated inputs and it may be possible to run without screened cables, noise could be picked up by cables resulting in spurious input triggers. Remember that all inputs are relatively low current, therefore wires should be of suitable thickness i.e. 0.5 mm. All connectors used must also be suitable for low current use.

Wiring to Drivers

Each driver may carry different loads and for the majority of cases 16/0.2mm cable is sufficient. Screened cable is preferred in order to meet CE and other regulations and should be terminated appropriately.

Screening is also a good idea since noise spikes which may be picked up on the 24 volt rail may be radiated around the system resulting in EMC problems. Again all screens should be connected at one end of the cable only.

Make sure that there are no earth loops in the wiring system.

Analogue Input Wiring

The analogue inputs to the controller are normally best run separately in a screened cable that is suitably earthed to a star ground or similar.

General

This section covers other aspects of hardware that are not covered under the IO sections.

Keypad

The controller's keypad is designed to withstand harsh environments and is based on a printed circuit board design with individual tactile switches for each key. When pressed, the key top sits flush with the fascia aluminium plate, preventing excessive pressure from damaging the key-switch.

Keys are rated to a minimum of 100,000 operations and are a high force actuation type to provide enhanced feedback to the operator should they need to wear gloves.

Keypad LED's

The controller also has eight standard LED's which can be used as warning messages or as status messages for the operator. One LED, labelled 'KEY', is committed to indicating a key press. The remaining seven LED's are selected within the program via LED command as required by the system programmer.

Normally the Power LED would be on and the READY LED would be used when running a program. These can be changed by using the LED command.

Depending on the keypad style selected there may be other LED's provided e.g. spindle on/off, Caps Lock, Symbol Shift etc.

Overlay

The overlay is manufactured from polycarbonate and is extremely immune to most industrial substances, however the keypad should not be operated with sharp objects or and should not come into contact with solvents or other substances which may affect plastics. Should you wish to be advised further about suitability with chemicals involved in your process, please contact TRM for further advice.

Power Supply

The controller has an internal switch mode power supply which will operate from 7.5 volts up to a limit of 36 volts DC and should be fused externally at 2 amps. This enables the controller to be run from an unregulated 24 volt rail, providing it does not exceed the above specification. Under no circumstances must a voltage in excess of 36 volts be applied to the power supply or serious damage may occur as the controller is fitted with protection devices which clamp the input voltage.

The controller has a capacitor bank on-board which it uses to freewheel inductive currents back to. In some cases external switch mode power supplies feeding this load may trip out, in which case a lone power resistor of 0.5 ohms may be required in the positive supply line to limit current surge. The simplest form of power supply, consists of:

- A transformer with an 18 volt secondary winding
- A bridge rectifier
- A smoothing capacitor of around 10,000 uF
- Compliant fusing and filters

It is recommended that a discharge resistor of around 47K ohms be connected across the smoothing capacitor to avoid damage should it be shorted out when the power is turned off.

Pinout Connections

Below are listed the pinout connections for the PMC controller.

37 way D Male		
Pin	Signal	Description
1	GND	Controller Supply
2	+24V DC	Controller Supply
3	VDDIO	Normally +24VDC
4	VDDIO	Normally +24VDC
5	VDDIO	Normally +24VDC
6	VDDIO	Normally +24VDC
7	VDDIO	Normally +24VDC
8	DRV 8	Driver output
9	DRV 9	Driver output
10	DRV 10	Driver output
11	DRV 11	Driver output
12	DRV 12	Driver output
13	DRV 13	Driver output
14	DRV 14	Driver output
15	DRV 15	Driver output
16	DRV 16 / INP 16	Driver output / Optional Input
17	DRV 17 / INP 17	Driver output / Optional Input
18	DRV 18 / INP 18	Driver output / Optional Input
19	DRV 19 / INP 19	Driver output / Optional Input
20	GND	Linked to Pin 1
21	+24V DC	Linked to Pin 2
22	INP 0	Opto Isolated Digital Input
23	INP 1	Opto Isolated Digital Input
24	INP 2	Opto Isolated Digital Input
25	INP 3	Opto Isolated Digital Input
26	INP 4	Opto Isolated Digital Input
27	INP 5	Opto Isolated Digital Input
28	INP 6	Opto Isolated Digital Input

29	INP 7	Opto Isolated Digital Input
30	INP 8	Opto Isolated Digital Input
31	INP 9	Opto Isolated Digital Input
32	INP 10	Opto Isolated Digital Input
33	INP 11	Opto Isolated Digital Input
34	INP 12	Opto Isolated Digital Input
35	INP 13	Opto Isolated Digital Input
36	INP 14	Opto Isolated Digital Input
37	INP 15	Opto Isolated Digital Input
Shell	Screen	Connect cable screens to shell

44 way D Female		
Pin	Signal	Description
1	A0	Encoder Channel
2	B0	Encoder Channel
3	Z0	Encoder Channel
4	A1	Encoder Channel
5	B1	Encoder Channel
6	Z1	Encoder Channel
7	A2	Encoder Channel
8	B2	Encoder Channel
9	Z2	Encoder Channel
10	A3	Encoder Channel
11	B3	Encoder Channel
12	Z3	Encoder Channel
13	Step0 / TTL1	Stepper / TTL Driver
14	Step2 / TTL5	Stepper / TTL Driver
15	GND	Ground
16	+5VE	Encoder Supply
17	A0\	Encoder Channel
18	B0\	Encoder Channel
19	AGND	Analogue Ground

20	A1\	Encoder Channel
21	B1\	Encoder Channel
22	+5VE	Encoder Supply
23	A2\	Encoder Channel
24	B2\	Encoder Channel
25	AGND	Analogue Ground
26	A3\	Encoder Channel
27	B3\	Encoder Channel
28	AGND	Analogue Ground
29	Step1 / TTL3	Stepper / TTL Driver
30	Step3 / TTL7	Stepper / TTL Driver
31	MC0	Motion Control Output
32	MC1	Motion Control Output
33	MC2	Motion Control Output
34	MC3	Motion Control Output
35	ADC0	Analogue Input
36	ADC1	Analogue Input
37	ADC2	Analogue Input
38	ADC3	Analogue Input
39	DIR0 / TTL0	Stepper Direction / TTL Driver
40	DIR1 / TTL2	Stepper Direction / TTL Driver
41	DIR2 / TTL4	Stepper Direction / TTL Driver
42	DIR3 / TTL6	Stepper Direction / TTL Driver
43	ENA C	Opto Isolated Collector
44	ENA E	Opto Isolator Emitter
Shell	Screen	Connect cable screens to shell

15 way D Female		
Pin	Signal	Description
1	RX	RS232
2	TX	RS232
3	RTS	RS232

4	CTS	RS232
5	GND	
6	A	RS485
7	B	RS485
8	Y	RS485
9	Z	RS485
10	GND	
11	CAN H	CAN BUS
12	CAN L	CAN BUS
13	N/C	
14	N/C	
15	GND	
Shell	Screen	Connect cable screens to shell